



IN COOPERATION WITH NGI®

N38624 SCPI

N38624 Series Programming Guide SCPI Protocol

SCPI

Offizieller Partner von NGI: Service und Vertrieb direkt durch ET System electronic GmbH.
Official partner of NGI: Service and sales directly through ET System electronic GmbH.

ET System electronic GmbH
www.et-system.de

Hauptstraße 119 - 121
D - 68804 Altlußheim

Vertrieb Kontakt: Tel.: +49 (0)6205 / 394 80
Sales contact: info@et-system.de

Contents

CONTENTS	1
1 PREFACE	1
2 SAFETY INSTRUCTIONS	2
2.1 Safety Notes	2
2.2 Safety Symbols	2
3 OVERVIEW	3
4 COMMUNICATION CONFIGURATION	3
5 PROGRAMMING COMMAND OVERVIEW	3
5.1 Brief Introduction	3
5.2 Syntax	4
5.2.1 Command Keyword	5
5.2.2 Command Separator	5
5.2.3 Query	6
5.2.4 Command Terminator	6
5.3 Parameter Format	7
6 COMMANDS	7
6.1 IEEE 488.2 Common Commands	7
6.2 Measure Commands	8
6.3 Output Commands	11
6.4 Source Commands.....	13
6.5 Charge Commands	14
6.6 SEQ Commands	17
6.7 SOC Commands	24
6.8 Protection.....	29
6.9 CAN Setting.....	30
7 PROGRAMMING EXAMPLES	32
7.1 Source Mode	32
7.2 Charge Mode	33
7.3 SOC Test.....	33
7.4 SEQ Mode	34
7.5 Measurement	35
7.6 Factory Reset.....	36
8 ERROR INFORMATION	36
8.1 Command Error	36
8.2 Execution Error	38

1 Preface

Dear Customers,

First of all, we greatly appreciate your choice of N83624 series battery simulator (N83624 for short). We are also honored to introduce our company, Hunan Next Generation Instrumental T&C Tech. Co., Ltd. (NGI for short).

About Company

NGI is a professional manufacturer of intelligent equipment and test & control instruments, mainly engaged in design, production, sales, installations and maintenance of instruments and meters, electronic products, mechanical equipment, automatic test systems, computer software, automatic control equipment, automatic monitoring and alarm systems.

NGI maintains close cooperation with many universities and scientific research institutions, and maintains close ties with many industry leaders. We strive to develop high-quality, technology-leading products, provide high-end technologies, and continue to explore new industry measurement and control solutions.

About Manual

This manual is applied to N83624 series battery simulator, including programming guide based on standard SCPI protocol. The copyright of the manual is owned by NGI. Due to the upgrade of instrument, this manual may be revised without notice in future versions.

This manual has been reviewed carefully by NGI for the technical accuracy. The manufacturer declines all responsibility for possible errors in this operation manual, if due to misprints or errors in copying. The manufacturer is not liable for malfunctioning if the product has not correctly been operated.

To ensure the safety and correct use of N83624, please read this manual carefully, especially the safety instructions.

Please keep this manual for future use.

Thanks for your trust and support.

2 Safety Instructions

In the operation and maintenance of the instrument, please strictly comply with the following safety instructions. Any performance regardless of attentions or specific warnings in other chapters of the manual may impair the protective functions provided by the instrument.

NGI shall not be liable for the results caused by the neglect of those instructions.















2.1 Safety Notes

- **Confirm the AC input voltage before supplying power.**
- **Reliable grounding:** Before operation, the instrument must be reliably grounded to avoid the electric shock.
- **Confirm the fuse:** Ensure to have installed the fuse correctly.
- **Do not open the chassis:** The operator cannot open the instrument chassis. Non-professional operators are not allowed to maintain or adjust it.
- **Do not operate under hazardous conditions:** Do not operate the instrument under flammable or explosive conditions.
- **Confirm the working range:** Make sure the DUT is within N83624's rated range.

2.2 Safety Symbols

Please refer to the following table for definitions of international symbols used on the instrument or in the user manual.

Table 1

Symbol	Definition	Symbol	Definition
	DC (direct current)	N	Null line or neutral line
	AC (alternating current)	L	Live line
	AC and DC	I	Power-on
	Three-phase current		Power-off
	Ground		Back-up power
	Protective ground		Power-on state
	Chassis ground		Power-off state
	Signal ground		Risk of electric shock
WARNING	Hazardous sign		High temperature warning
Caution	Be careful		Warning

3 Overview

N83624 series battery simulators provide LAN port and RS232 interface. Users can connect N83624 and PC by the corresponding communication line to realize control.

4 Communication Configuration

Communication protocol: standard SCPI

Communication method: LAN, RS232

Default IP address: 192.168.0.123 (It can be adjusted. It will take effect after restart.)

UDP port number: 7000-7024

Note: Port 7000 is communication board, which can also control 24 channels. Port 7001 to 7024 corresponds to channel 1 to 24. It is recommended that users who have requirements for data collection speed communicate through ports 7001-7024.

TCP port number: 7000

Default baud rate: 115200 (It can be adjusted. It will take effect after restart.)

5 Programming Command Overview

5.1 Brief Introduction

N83624 commands include two types: IEEE488.2 public commands and SCPI commands.

IEEE 488.2 public commands define some common control and query commands for instruments. Basic operation on N83624 can be achieved through public commands, such as reset, status query, etc. All IEEE 488.2 public commands consist of an asterisk (*) and three-letter mnemonic: *RST, *IDN ?, *OPC ?, etc.

SCPI commands can implement most of N83624 functions of testing, setting, calibration and measurement. SCPI commands are organized in the form of a command tree. Each command can contain multiple mnemonics, and each node of the command tree is separated by a colon (:), as shown in the below figure. Top of the command tree is called ROOT. The full path from ROOT to the leaf node is a complete programming command.

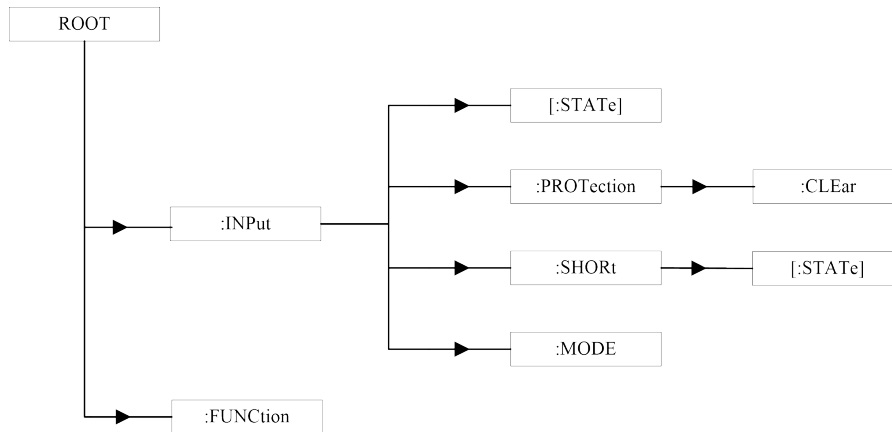

Figure 1 Command Tree Example

5.2 Syntax

N83624 SCPI commands are the inheritance and expansion of IEEE 488.2 commands. SCPI commands consist of command keywords, separators, parameter fields and terminators. Take the following command as an example:

SOURce<n>:VOLTage 2.5

In this command, SOURce and VOLTage are command keywords. n is channel number 1 to 24. The colon (:) and space are separators. 2.5 is the parameter field. The carriage return is terminator. Some commands have multiple parameters. The parameters are separated by a comma (,).

MEASure:VOLTage?(@1,2)

This command means obtaining readback voltage of channel 1 and 2. Number 1 and 2 means channel number, which are separated by a comma.

Reading readback voltage of 24 channels at the same time:

```
MEASure:VOLTage?(@1,2,3,4,5,6,7,8,9,10,11,12,13,14,15,16,17,18,19,20,21,22,23,24
)
```

Writing constant voltage value to 5V of 24 channels at the same time:

```
SOURce:VOLTage
5(@1,2,3,4,5,6,7,8,9,10,11,12,13,14,15,16,17,18,19,20,21,22,23,24)
```

For the convenience of description, the symbols in the subsequent chapters will be applicable to the following conventions.

- ◆ Square brackets ([]) indicate optional keywords or parameters, which can be

omitted.

- ◆ Curly brackets ({}) indicate the parameter options in the command string.
- ◆ Angle brackets (<>) indicate that a numeric parameter must be provided.
- ◆ The vertical line (|) is used to separate the options of multiple optional parameters.

5.2.1 Command Keyword

Each command keyword has two formats: long mnemonic and short mnemonic. Short mnemonic is short for long mnemonic. Each mnemonic should not exceed 12 characters, including any possible numeric suffixes. The battery simulator only accepts precisely long or short mnemonics.

The rules for generating mnemonics are as follows:

1. Long mnemonics consist of one word or phrase. If it is a word, the entire word constitutes a mnemonic.

Examples:

CURRENT — **CURRent**

2. Short mnemonics generally consist of the first 4 characters of long mnemonics.

Example:

CURRent — **CURR**

3. If the character length of long mnemonic is less than or equal to 4, long and short mnemonics are the same. If the character length of long mnemonic is greater than 4 and the fourth character is a vowel, short mnemonic will be composed of 3 characters, discarding the vowel.

Examples:

MODE — **MODE**

POWer — **POW**

4. Mnemonics are not case sensitive.

5.2.2 Command Separator

1. Colon (:)

Colon is used to separate two adjacent keywords in the command, such as separating **SOUR1** and **VOLT** in command **SOUR1:VOLT 2.54**.

Colon can also be the first character of a command, indicating it will seek path from the top node of command tree.

2. Space

Space is used to separate command field and parameter field.

3. Semicolon (;)

Semicolon is used to separate multiple command units when multiple command units are included in one command. The level of the present path does not change by using a semicolon.

Example:

SOUR1:VOLT 2.54;OUTCURR 1000

The above command is to set constant voltage value to 2.54V and output current limit to 1000mA in source mode. The above command is equivalent to the following two commands:

SOUR1:VOLT 2.54

SOUR1:OUTCURR 1000

4. Semicolon and Colon (;:)

It is used to separate multiple commands.

MEASure:VOLTage?;:SOURce:VOLTage 10;:OUTPut:ONOFF 1

5.2.3 Query

Question mark (?) is used to mark the query function. It follows the last keyword of the command field. For example, for querying constant voltage of channel 1 in source mode, the query command is **SOUR1:VOLT?**. If the constant voltage is 5V, the battery simulator will return a character string **5**.

After the battery simulator receives the query command and completes the analysis, it will execute the command and generate a response string. The response string is first written into the output buffer. If the present remote interface is a GPIB interface, it waits for the controller to read the response. Otherwise, it immediately sends the response string to the interface.

Most commands have corresponding query syntax. If a command cannot be queried, the battery simulator will report an error message **-115 Command can not query** and nothing will be returned.

5.2.4 Command Terminator

The command terminators are line feed character (ASCII character LF, value 10) and EOI (only for GPIB interface). The terminator function is to terminate the present

command string and reset the command path to the root path.

5.3 Parameter Format

Parameter programmed are represented by ASCII code in the types of numeric, character, bool, etc.

Table 2

Symbol	Description	Example
<NR1>	Integer value	123
<NR2>	Floating point value	123., 12.3, 0.12, 1.23E4
<NRf>	The value may be NR1 or NR2.	
<NRf+>	Expanded value format that includes <NRf>, MIN and MAX.	
<Bool>	Boolean data	1 0 ON OFF
<CRD>	Character data, for example, CURR	
<AARD>	Return ASCII code data, allowing the return of undefined 7-bit ASCII. This data type has an implied command terminator.	

6 Commands

6.1 IEEE 488.2 Common Commands

Common commands are general commands required by IEEE 488.2 standard that instruments must support. They are used to control the general functions of instruments, such as reset and status query. Its syntax and semantics follow IEEE 488.2 standard. IEEE 488.2 common commands have no hierarchy.

*IDN?

This command reads information of the battery simulator. It returns the data in four fields separated by commas. The data include manufacturer, model, reserved field and software version.

Query Syntax

*IDN?

Parameters

None

Returns

<AARD>	String	Description
	NGITECH	Manufacturer
	N83624	Model
	0	Reserved field
	XX.XX	Software version

Returns Example NGITECH,N83624,0,V1.00

***OPC**

This command sets the Operation Complete (OPC) bit in the Standard Event Register to 1 when all operations and commands are completed.

Command Syntax	*OPC
Parameters	None
Query Syntax	*OPC?
Returns	<NR1>
Related Commands	*TRG *WAI

***RST**

This command is used to restore factory settings.

Command Syntax	*RST
Parameters	None
Returns	None
Related Commands	None

6.2 Measure Commands

MEASure<n>:CURRent?

This command queries the readback current of corresponding channel.

Command Syntax	MEASure<n>:CURRent?
Parameters	<n> N refers to channel number. The range is from 1 to 24.
Example	MEAS1:CURR?
Returns	<NRf>
Unit	mA

MEASure<n>:VOLTage?

This command queries the readback voltage of corresponding channel.

Command Syntax MEASure<n>:VOLTage?

Parameters <n> N refers to channel number. The range is from 1 to 24.

Example MEAS1:VOLT?

Returns <NRf>

Unit V

MEASure<n>:POWER?

This command queries the readback power of corresponding channel.

Command Syntax MEASure<n>:POWER?

Parameters <n> N refers to channel number. The range is from 1 to 24.

Example MEAS1:POW?

Returns <NRf>

Unit W

MEASure<n>:MAH?

This command queries the capacity of corresponding channel.

Command Syntax MEASure<n>: MAH?

Parameters <n> N refers to channel number. The range is from 1 to 24.

Example MEAS1: MAH?

Returns <NRf>

Unit mAh

MEASure<n>:Res?

This command queries the resistance value of corresponding channel.

Command Syntax MEASure<n>:Res?

Parameters <n> N refers to channel number. The range is from 1 to 24.

Example MEAS1:R?

Returns <NRf>

Unit m Ω

MEASure<n>:CAPRate?

This command queries the sense/sampling rate.

Command Syntax MEASure<n>:CAPR <NR1>

Parameters <n> N refers to sense rate. The range is from 0 to 2. NR1 range is 0|1|2.

Example MEAS1:CAPR 1

Query Syntax MEAS1:CAPR?

Returns 0 for 10ms, 1 for 120ms, 2 for 480ms

6.3 Output Commands

OUTPut<n>:MODE

This command is used to set the operation mode of corresponding channel.

Command Syntax OUTPut<n>:MODE<NR1>

Parameters <n> N refers to channel number. The range is from 1 to 24.
NR1 Range: 0|1|3|128

Example OUTP1:MODE 1

Query Syntax OUTP1:MODE?

Returns 0 for source mode
1 for charge mode
3 for SOC mode
128 for SEQ mode

OUTPut<n>:ONOFF

This command turns on or off the output of corresponding channel.

Command Syntax OUTPut<n>:ONOFF < NR1>

Parameters <n> N refers to channel number. The range is from 1 to 24.
NR1 Range: 1|0

Example OUTP1:ONOFF 1

Query Syntax OUTP1:ONOFF?

Returns 1 for ON
 0 for OFF

OUTPut<n>:STATe?

This command queries operating state of corresponding channel.

Command Syntax OUTPut<n>:STATe?

Parameters <n> N refers to channel number. The range is from 1 to 24.

Query Syntax OUTP1:STAT?

Returns Channel state
 Bit0: ON/OFF state
 Bit16-18: readback value range, 0 for high range, 1 for medium
 range, 2 for low range

6.4 Source Commands

SOURce<n>:VOLTage

This command is used to set output constant voltage.

Command Syntax	SOURce<n>:VOLTage <NRf>
Parameters	<n> N refers to channel number. The range is from 1 to 24. NRf Range: MIN~MAX
Example	SOUR1:VOLT 2.54
Query Syntax	SOUR1:VOLT?
Returns	<NRf>
Unit	V

SOURce<n>:OUTCURREnt

This command is used to set output current limit.

Command Syntax	SOURce<n>:OUTCURREnt <NRf>
Parameters	<n> N refers to channel number. The range is from 1 to 24. NRf Range: MIN~MAX
Example	SOUR1:OUTCURR 1000
Query Syntax	SOUR1:OUTCURR?
Returns	<NRf>
Unit	mA

SOURce<n>:RANGe

This command is used to set current range.

Command Syntax SOURce<n>:RANGe <NR1>

Parameters <n> N refers to channel number. The range is from 1 to 24.
NR1 Range: 0|2|3

Example SOUR1:RANG 1

Query Syntax SOUR1:RANG?

Returns 0 for high range
2 for low range
3 for auto range

6.5 Charge Commands

CHARge<n>:VOLTage

This command is used to set output constant voltage under charge mode.

Command Syntax CHARge<n>:VOLTage <NRf>

Parameters <n> N refers to channel number. The range is from 1 to 24.
NRf Range: MIN~MAX

Example CHAR1:VOLT 5.6

Query Syntax CHAR1:VOLT?

Returns <NRf>

Unit V

CHARge<n>:OUTCURRent

This command is used to set output current limit under charge mode.

Command Syntax	CHARge<n>:OUTCURRent <NRf>
Parameters	<n> N refers to channel number. The range is from 1 to 24. NRf Range: MIN~MAX
Example	CHAR1:OUTCURR 2000
Query Syntax	CHAR1:OUTCURR?
Returns	<NRf>
Unit	mA

CHARge<n>:Res

This command is used to set resistance value under charge mode.

Command Syntax	CHARge<n>:Res <NRf>
Parameters	<n> N refers to channel number. The range is from 1 to 24. NRf Range: MIN~MAX
Example	CHAR1:R 0.2
Query Syntax	CHAR1:R ?
Returns	<NRf>
Unit	mΩ

CHARge<n>:ECHO:VOLTage?

This command queries readback voltage under charge mode.

Command Syntax CHARge<n>:ECHO:VOLTage

Parameters <n> N refers to channel number. The range is from 1 to 24.

Example CHAR1:ECHO:VOLTage?

Returns <NRf>

Unit V

CHARge<n>:ECHO:Q?

This command queries readback capacity under charge mode.

Command Syntax CHARge<n>:ECHO:Q

Parameters <n> N refers to channel number. The range is from 1 to 24.

Example CHAR1:ECHO:Q?

Returns <NRf>

Unit mAh

6.6 SEQ Commands

SEQuence<n>:EDIT:FILE

This command is used to set sequence file number.

Command Syntax SEQuence<n>:EDIT:FILE <NR1>

Parameters <n> N refers to channel number. The range is from 1 to 24.
NR1 Range: file number 1 to 10

Example SEQ1:EDIT:FILE 3

Query Syntax SEQ1:EDIT:FILE?

Returns <NR1>

SEQuence<n>:EDIT:LENGth

This command is used to set total steps in the sequence file.

Command Syntax SEQuence<n>:EDIT:LENGth <NR1>

Parameters <n> N refers to channel number. The range is from 1 to 24.
NR1 Range: 0~200

Example SEQ1:EDIT:LENG 20

Query Syntax SEQ1:EDIT:LENG?

Returns <NR1>

SEQuence<n>:EDIT:STEP

This command is used to set the specific step number.

Command Syntax SEQuence<n>:EDIT:STEP <NR1>

Parameters <n> N refers to channel number. The range is from 1 to 24.
NR1 Range: 1~200

Example SEQ1:EDIT:STEP 5

Query Syntax SEQ1:EDIT:STEP?

Returns <NR1>

SEQuence<n>:EDIT:CYCLE

This command is used to set the cycle times for the file under editing.

Command Syntax SEQuence<n>:EDIT:CYCLE <NR1>

Parameters <n> N refers to channel number. The range is from 1 to 24.
NR1 Range: 0~100

Example SEQ1:EDIT:CYCLE 0

Query Syntax SEQ1:EDIT:CYCLE ?

Returns <NR1>

SEQuence<n>:EDIT:VOLTage

This command is used to set the output voltage for the step under editing.

Command Syntax SEQuence<n>:EDIT:VOLTage<NRf>

Parameters <n> N refers to channel number. The range is from 1 to 24.
NRf Range: MIN~MAX

Example SEQ1:EDIT:VOLT 5

Query Syntax SEQ1:EDIT:VOLT?

Returns <NRf>

Unit V

SEQuence<n>:EDIT:OUTCURRent

This command is used to set the output current limit for the step under editing.

Command Syntax SEQuence<n>:EDIT:OUTCURRent<NRf>

Parameters <n> N refers to channel number. The range is from 1 to 24.
NRf Range: MIN~MAX

Example SEQ1:EDIT:OUTCURR 500

Query Syntax SEQ1:EDIT:OUTCURR?

Returns <NRf>

Unit mA

SEQuence<n>:EDIT:Res

This command is used to set the resistance for the step under editing.

Command Syntax SEQuence<n>:EDIT:Res<NRf>

Parameters <n> N refers to channel number. The range is from 1 to 24.
NRf Range: MIN~MAX

Example SEQ1:EDIT:R 0.4

Query Syntax SEQ1:EDIT:R?

Returns <NRf>

Unit mΩ

SEQuence<n>:EDIT:RUNTime

This command is used to set the running time for the step under editing.

Command Syntax SEQuence<n>:EDIT:RUNTime<NRf>

Parameters <n> N refers to channel number. The range is from 1 to 24.
NRf Range: MIN~MAX

Example SEQ1:EDIT:RUNT 5

Query Syntax SEQ1:EDIT:RUNT ?

Returns <NRf>

Unit s

SEQuence<n>:EDIT:LINKStart

This command is used to set the required link start step after the present step is completed.

Command Syntax SEQuence<n>:EDIT:LINKStart<NR1>

Parameters <n> N refers to channel number. The range is from 1 to 24.
NR1 Range: -1~200

Example SEQ1:EDIT:LINKS -1

Query Syntax SEQ1:EDIT:LINKS?

Returns <NR1>

SEQuence<n>:EDIT:LINKEnd

This command is used to set the link stop step for the step under editing.

Command Syntax SEQuence<n>:EDIT:LINKEnd<NR1>

Parameters <n> N refers to channel number. The range is from 1 to 24.
NR1 Range: -1~200

Example SEQ1:EDIT:LINKE-1

Query Syntax SEQ1:EDIT:LINKE?

Returns <NR1>

SEquence<n>:EDIT:LINKCycle

This command is used to set cycle times for the link.

Command Syntax SEquence<n>:EDIT:LINKCycle<NR1>

Parameters <n> N refers to channel number. The range is from 1 to 24.
NR1 Range: 0~100

Example SEQ1:EDIT:LINKC 5

Query Syntax SEQ1:EDIT:LINKC?

Returns <NR1>

SEquence<n>:RUN:FILE

This command is used to set the sequence test file number.

Command Syntax SEquence:RUN:FILE <NR1>

Parameters <n> N refers to channel number. The range is from 1 to 24.
NR1 Range: file number 1 to 10

Example SEQ1:RUN:FILE 3

Query Syntax SEQ1:RUN:FILE?

Returns <NR1>

SEQuence<n>:RUN:STEP?

This command is used to query the present running step number.

Command Syntax SEQuence<n>:RUN:STEP?

Parameters <n> N refers to channel number. The range is from 1 to 24.

Query Syntax SEQ1:RUN:STEP?

Returns <NR1>

SEQuence<n>:RUN:Cycle

This command is used to query the sequence running cycles.

Command Syntax SEQuence<n>:EDIT:Cycle?

Parameters <n> N refers to channel number. The range is from 1 to 24.

Query Syntax SEQ1:RUN:C?

Returns <NR1>

SEQuence<n>:RUN:Time?

This command is used to query the running time for the sequence test file.

Command Syntax SEQuence<n>:RUN:Time?

Parameters <n> N refers to channel number. The range is from 1 to 24.

Query Syntax SEQ1:RUN:T?

Returns <NRf>

Unit s

6.7 SOC Commands

SOC<n>:EDIT:LENGth

This command is used to set the total operation steps.

Command Syntax SOC<n>:EDIT:LENGth<NR1>

Parameters <n> N refers to channel number. The range is from 1 to 24.
NR1 Range: 0-200

Example SOC1:EDIT:LENG 3

Query Syntax SOC1:EDIT:LENG?

Returns <NR1>

SOC<n>:EDIT:STEP

This command is used to set the specific step number.

Command Syntax SOC<n>:EDIT:STEP<NR1>

Parameters <n> N refers to channel number. The range is from 1 to 24.
NR1 Range: 1-200

Example SOC1:EDIT:STEP 1

Query Syntax SOC1:EDIT:STEP?

Returns <NR1>

SOC<n>:EDIT:VOLTage

This command is used to set voltage value for the step under editing.

Command Syntax SOC<n>:EDIT:VOLTage<NRf>

Parameters <n> N refers to channel number. The range is from 1 to 24.
NRf Range: MIN~MAX

Example SOC1:EDIT:VOLT 2.8

Query Syntax SOC1:EDIT:VOLT?

Returns <NRf>

Unit V

SOC<n>:EDIT:OUTCURREnt

This command is used to set output current limit for the step under editing.

Command Syntax	SOC<n>:EDIT:OUTCURREnt<NRf>
Parameters	<n> N refers to channel number. The range is from 1 to 24. NRf Range: MIN~MAX
Example	SOC1:EDIT:OUTCURREnt 2000
Query Syntax	SOC1:EDIT:OUTCURREnt?
Returns	<NRf>
Unit	mA

SOC<n>:EDIT:Res

This command is used to set resistance value for the step under editing.

Command Syntax	SOC<n>:EDIT:Res<NRf>
Parameters	<n> N refers to channel number. The range is from 1 to 24. NRf Range: MIN~MAX
Example	SOC1:EDIT:Res 0.8
Query Syntax	SOC1:EDIT:Res?
Returns	<NRf>
Unit	mΩ

SOC<n>:EDIT:Q?

This command is used to set the capacity for the step under editing.

Command Syntax SOC<n>:EDIT:Q<NRf>

Parameters <n> N refers to channel number. The range is from 1 to 24.
NRf Range: MIN~MAX

Query Syntax SOC1:EDIT:Q?

Returns <NRf>

Unit mAh

SOC<n>:EDIT:SVOLTage

This command is used to set the initial/start voltage.

Command Syntax SOC<n>:EDIT:SVOLTage<NRf>

Parameters <n> N refers to channel number. The range is from 1 to 24.
NRf Range: MIN~MAX

Example SOC1:EDIT:SVOL 0.8

Query Syntax SOC1:EDIT:SVOL?

Returns <NRf>

Unit V

SOC<n>:RUN:STEP?

This command is used to query the present running step.

Command Syntax SOC<n>:RUN:STEP?

Parameters <n> N refers to channel number. The range is from 1 to 24.

Query Syntax SOC1:RUN:STEP?

Returns <NR1>

SOC<n>:RUN:Q?

This command is used to query the present capacity for the present running step.

Command Syntax SOC<n>:RUN:Q?

Parameters <n> N refers to channel number. The range is from 1 to 24.

Query Syntax SOC1:RUN:Q?

Returns <NRf>

Unit mAh

6.8 Protection

PRO<n>:CURRent

This command is used to query the OCP current.

Command Syntax	PRO<n>:CURRent <NRf>
Parameters	<n> N refers to channel number. The range is from 1 to 24. NRf range: MIN~MAX
Sample	PRO1:CURR 1000
Query Syntax	PRO1:CURR?
Returns	<NRf>
Unit	mA

PRO<n>:VOLTage

This command is used to query the OVP voltage.

Command Syntax	PRO<n>:VOLTage <NRf>
Parameters	<n> N refers to channel number. The range is from 1 to 24. NRf range: MIN~MAX
Sample	PRO1:VOLT 5
Query Syntax	PRO1:VOLT?
Returns	<NRf>
Unit	V

PRO<n>:POWER

This command is used to query the OPP power.

Command Syntax PRO<n>:POWER <NRf>

Parameters <n> N refers to channel number. The range is from 1 to 24.
NRf range: MIN~MAX

Sample PRO1:POWE 3000

Query Syntax PRO1:POWE?

Returns <NRf>

Unit mW

6.9 CAN Setting

CFG<n>:CANID?

This command is used to query CAN ID.

Command Syntax CFG<n>:CANID?

Parameters <n> N refers to channel number. The range is from 1 to 24.

Query Syntax CFG1:CANID?

Returns <NR1>

CFG<n>:UPTime

This command is used to set active upload time .

Command Syntax CFG<n>:UPTime<NR1>

Parameters <n> N refers to channel number. The range is from 1 to 24.
 NR1 range: 0 for off, minimum time interval over 60

Sample CFG1:UPT 60

Query Syntax CFG1:UPT?

Returns <NR1>

Unit ms

CFG<n>:CANRate?

This command is used to set CAN baud rate.

Command Syntax CFG<n>:CANRate?

Parameters <n> N refers to channel number. The range is from 1 to 24.

Query Syntax CFG1:CANR?

Returns <NR1>

CFG<n>:EXTCanid?

This command is used to query extension ID address.

Command Syntax CFG<n>:EXTCanid?

Parameters <n> N refers to channel number. The range is from 1 to 24.

Query Syntax CFG1:CANR?

Returns <NR1>

7 Programming Examples

This chapter will describe how to control the battery simulator by programming commands.

Note 1: In this chapter, there are comments starting with //, following some commands. These comments cannot be recognized by the battery simulator, only for the convenience of understanding the corresponding commands. Therefore, it is not allowed to input comments including // in practice.

Note 2: There are 24 channels in total. For the below programming examples, it demonstrates functions of only channel number one.

7.1 Source Mode

Under Source mode, constant voltage and current limit value can be set.

Example: set the battery simulator to Source mode, CV value to 5V, output current limit to 1000mA and current range to Auto.

```
OUTPut1:ONOFF 0            //turn off the output for present channel
OUTPut1:MODE 0            //set operation mode to Source mode
SOURce1:VOLTage 5.0        //set CV value to 5.0 V
SOURce1:OUTCURRent 1000    //set output current limit to 1000mA
SOURce1:RANGe 3            //select 3-Auto for current range
```

OUTPut1:ONOFF 1 //turn on the output for channel 1

7.2 Charge Mode

Under Charge mode, constant voltage, current limit and resistance value can be set. The current range under charge mode is fixed as high range.

Example: set the battery simulator to Charge mode, CV value to 5V, output current limit to 1000mA and resistance value to 3.0mΩ.

```
OUTPut1:ONOFF 0 //turn off the output for present channel
OUTPut1:MODE 1 //set operation mode to Charge mode
CHARge1:VOLTage 5.0 //set CV value to 5.0 V
CHARge1:OUTCURRENT 1000 //set output current limit to 1000mA
CHARge1: Res 3.0 //set resistance value to 3.0mΩ
OUTPut1:ONOFF 1 //turn on the output for channel 1
```

7.3 SOC Test

The main function of N83624 SOC test is to simulate battery discharge function. Users need to input various parameters of battery discharge into the corresponding channels, such as capacity, constant voltage value, output current limit, and resistance value. The battery simulator judges whether the capacity difference of present running step and the next step is equal, according to the capacity of present running step. If equal, N83624 will move to next step. If not equal, N83624 will continue to accumulate the capacity for present running step. The capacity is determined by the connected DUT, that is, the output current.

Example: set the battery simulator to SOC mode, total steps to 3 and initial voltage to 4.8V. The steps parameters are as below table.

Step No.	Capacity(mAh)	CV Value(V)	Current(mA)	Resistance(mΩ)
1	1200	5.0	1000	0.1
2	1000	2.0	1000	0.2
3	500	1.0	1000	0.3

```
OUTPut1:ONOFF 0 //turn off the output for present channel
OUTPut1:MODE 3 //set operation mode to SOC mode
SOC1:EDIT:LENGth 3 //set total steps to 3
SOC1:EDIT: STEP 1 //set step No. to 1
SOC1:EDIT: Q 1200 //set capacity for step No. 1 to 1200mAh
SOC1:EDIT: VOLTage 5.0 //set CV Value for step No. 1 to 5.0V
SOC1:EDIT: OUTCURRENT 1000 //set output current limit for step No. 1 to 1000mA
```

```

SOC1:EDIT: Res 0.1 //set resistance for step No. 1 to 0.1mΩ

SOC1:EDIT: STEP 2 //set step No. to 2
SOC1:EDIT: Q 1000 //set capacity for step No. 2 to 1000mAh
SOC1:EDIT: VOLTage 2.0 //set CV Value for step No. 2 to 2.0V
SOC1:EDIT: OUTCURREnt 1000 //set output current limit for step No. 2 to 1000mA
SOC1:EDIT: Res 0.2 //set resistance for step No. 2 to 0.2mΩ

SOC1:EDIT: STEP 3 //set step No. to 3
SOC1:EDIT: Q 500 //set capacity for step No. 3 to 500mAh
SOC1:EDIT: VOLTage 1.0 //set CV Value for step No. 3 to 1.0V
SOC1:EDIT: OUTCURREnt 1000 //set output current limit for step No. 3 to 1000mA
SOC1:EDIT: Res 0.3 //set resistance for step No. 3 to 0.3mΩ
SOC1:EDIT:SVOL 4.8 //set initial/start voltage to 4.8V
OUTPut1:ONOFF 1 //turn on the output for channel 1

SOC1 RUN: STEP? //read the present running step No.
SOC1: RUN:Q? //read the capacity for present running step

```

7.4 SEQ Mode

The SEQ test mainly judges the number of running steps based on the selected SEQ file. It will run all the steps in sequence, according to the preset output parameters for each step. Links can also be made between steps. The corresponding cycle times can be set independently.

Example: set the battery simulator to SEQ mode, SEQ file No. to 1, total steps to 3 and file cycle times to 1. The steps parameters are as below table.

Step No.	CV Value(V)	Current(mA)	Resistance(mΩ)	Time(s)	Link Start Step	Link Stop Step	Link Cycle Times
1	1	2000	0.0	5	-1	-1	0
2	2	2000	0.1	10	-1	-1	0
3	3	2000	0.2	20	-1	-1	0

```

OUTPut1:ONOFF 0 //turn off the output for present channel
OUTPut1:MODE 128 //set operation mode to SEQ mode
SEQuence1:EDIT:FILE 1 //set SEQ file No. to 1
SEQuence1:EDIT:LENGth 3 //set total steps to 3
SEQuence1:EDIT:CYCLE 1 //set file cycle times to 1
SEQuence1:EDIT:STEP 1 //set step No. to 1
SEQuence1:EDIT:VOLTage 1.0 //set CV Value for step No. 1 to 1.0V

```

```

SEquence1:EDIT:OUTCURREnt 2000 //set output current limit for step No. 1 to
2000mA
SEquence1:EDIT:Res 0.0 //set resistance for step No. 1 to 0mΩ
SEquence1:EDIT:RUNTime 5 //set running time for step No. 1 to 5s
SEquence1:EDIT:LINKStart -1 //set link start step for step No. 1 to -1
SEquence1:EDIT:LINKEnd -1 //set link stop step for step No. 1 to -1
SEquence1:EDIT:LINKCycle 0 //set link cycle times to 0

SEquence1:EDIT:STEP 2 //set step No. to 2
SEquence1:EDIT:VOLTage 2.0 //set CV Value for step No. 2 to 2.0V
SEquence1:EDIT:OUTCURREnt 2000 //set output current limit for step No. 2 to
2000mA
SEquence1:EDIT:Res 0.1 //set resistance for step No. 2 to 0.1mΩ
SEquence1:EDIT:RUNTime 10 //set running time for step No. 2 to 10s
SEquence1:EDIT:LINKStart -1 //set link start step for step No. 2 to -1
SEquence1:EDIT:LINKEnd -1 //set link stop step for step No. 2 to -1
SEquence1:EDIT:LINKCycle 0 //set link cycle times to 0
SEquence1:EDIT:STEP 3 //set step No. to 3
SEquence1:EDIT:VOLTage 3.0 //set CV Value for step No. 3 to 3.0V
SEquence1:EDIT:OUTCURREnt 2000 //set output current limit for step No. 3 to
2000mA
SEquence1:EDIT:Res 0.2 //set resistance for step No. 3 to 0.2mΩ
SEquence1:EDIT:RUNTime 20 //set running time for step No. 3 to 20s
SEquence1:EDIT:LINKStart -1 //set link start step for step No. 3 to -1
SEquence1:EDIT:LINKEnd -1 //set link stop step for step No. 3 to -1
SEquence1:EDIT:LINKCycle 0 //set link cycle times to 0

SEquence1:RUN:FILE 1 //set the running SEQ file No. to 1
OUTPut1:ONOFF 1 //turn on the output for channel 1
SEquence1: RUN:STEP? //read the present running step No.
SEquence1: RUN:T? //read running time for present SEQ file No.

```

7.5 Measurement

There is a high-precision measurement system inside the battery simulator to measure output voltage, current, power and temperature.

```

MEASure1:CURREnt? //Read the readback current for channel 1
MEASure1:VOLTage? //Read the readback voltage for channel 1
MEASure1:POWEr? //Read the real-time power for channel 1
MEASure1:TEMPerature? //Read the real-time temperature for channel 1
MEAS2:CURR? //Read the readback current for channel 2
MEAS2:VOLT? //Read the readback voltage for channel 2

```

MEAS2:POW? //Read the real-time power for channel 2
MEAS2:TEMP? //Read the real-time temperature for channel 2

7.6 Factory Reset

Execute *RST command to do factory reset on battery simulator.

8 Error Information

8.1 Command Error

- 100 **Command error** Undefined syntax error
- 101 **Invalid character** Invalid character in string
- 102 **Syntax error** Unrecognized command or data type
- 103 **Invalid separator** A separator is required. However the character sent is not a separator.
- 104 **Data type error** The present data type does not match the required type.
- 105 **GET not allowed** The group execution trigger (GET) is received in the program information.
- 106 **Semicolon unwanted** There are one or more extra semicolons.
- 107 **Comma unwanted** There are one or more extra commas.
- 108 **Parameter not allowed** The number of parameters exceeds the number required by the command.
- 109 **Missing parameter** The number of parameters is less than the number required by the command, or no parameters are inputted.
- 110 **Command header error** Undefined command header error
- 111 **Header separator error** A non-separator character is used in the place of the separator in the command header.

- 112 **Program mnemonic too long** The length of mnemonic exceeds 12 characters.
- 113 **Undefined header** Although the received command conforms to the regulations in terms of syntax structure, it is not defined in this instrument.
- 114 **Header suffix out of range** The suffix of command header is out of range.
- 115 **Command can not query** There is no query form for the command.
- 116 **Command must query** The command must be in query form.
- 120 **Numeric data error** Undefined numeric data error
- 121 **Invalid character in number** A data character that is not accepted by the current command appears in the numerical data.
- 123 **Exponent too large** The absolute value of exponent exceeds 32,000.
- 124 **Too many digits** Excluding the leading 0 in decimal data, the data length exceeds 255 characters.
- 128 **Numeric data not allowed** Numerical data in the correct format is received at a location that does not accept numerical data.
- 130 **Suffix error** Undefined suffix error
- 131 **Invalid suffix** The suffix does not follow the syntax defined in IEEE 488.2, or the suffix is not suitable for E5071C.
- 134 **Suffix too long** The suffix is longer than 12 characters.
- 138 **Suffix not allowed** A suffix is added to the values that are not allowed to be suffixed.
- 140 **Character data error** Undefined character data error
- 141 **Invalid character data** An invalid character was found in the character data, or an invalid character was received.

- 144 **Character data too long** The character data is longer than 12 characters.
- 148 **Character data not allowed** The character data in the correct format is received at the position where the instrument does not accept character data.
- 150 **String data error** Undefined string data error
- 151 **Invalid string data** The string data that appears is invalid for some reason.
- 158 **String data not allowed** String data is received at the position where this instrument does not accept string data.
- 160 **Block data error** Undefined block data error
- 161 **Invalid block data** The block data that appears is invalid for some reason.
- 168 **Block data not allowed** Block data is received at the position where this instrument does not accept block data.
- 170 **Expression error** Undefined expression error
- 171 **Invalid expression** The expression is invalid. For example, the brackets are not paired or illegal characters are used.
- 178 **Expression data not allowed** Expression data is received at the position where this instrument does not accept expression data.
- 180 **Macro error** Undefined macro error
- 181 **Invalid outside macro definition** There is a macro parameter placeholder \$ outside the macro definition.
- 183 **Invalid inside macro definition** There is syntax error in macro definition (*DDT,*DMC).
- 184 **Macro parameter error** Parameter number or parameter type is incorrect.

8.2 Execution Error

- 200 **Execution error** An error is generated that is related to execution and cannot be defined by this instrument.

-220	Parameter error	Undefined parameter error
-221	Setting conflict	The command was successfully parsed. But it can not be executed due to the current device status.
-222	Data out of range	Data is out of range.
-224	Illegal parameter value	The parameter is not included in the list of optional parameters for the current command.
-225	Out of memory	The available memory in this instrument is insufficient to perform the selected operation.
-232	Invalid format	Data format is invalid.
-240	Hardware error	Undefined hardware error
-242	Calibration data lost	Calibration data is lost.
-243	NO reference	There is no reference voltage.
-256	File name not found	The file name cannot be found.
-259	Not selected file	There are no optional files.
-295	Input buffer overflow	The input buffer is overflowing.
-296	Output buffer overflow	The output buffer is overflowing.